

8

7

6

5

4

3

2

1

ITEM NO.	PART NUMBER	DESCRIPTION	QTY.
1	EXTPRO-1 2000.01-2	Electronics mounting plate	1
2	EXTPRO-1 2000.02-2	Electronics box cover	2
3	EXTPRO-1 2000.03-2	Electronics box cover top right	1
4	EXTPRO-1 2000.04-2	Electronics box cover bottom left	1
5	Rittal Kx - 1533000 - 00.2	Electronics box, control panel	1
6	Rittal Kx - 1533000 - 00.1	Electronics Box Rittal	1
7	t0-2-15679_ea_svb		1
8	YW1B-V4E02R EMERGENCY STOP (IDEC)		1
9	RKC_REX_C100_temperature_control		3
10	024639		1
11	nac3mpxxa		4
12	zb4_bv013		1
13	Mini Thermocouple Jack	Mini Thermocouple jack	3

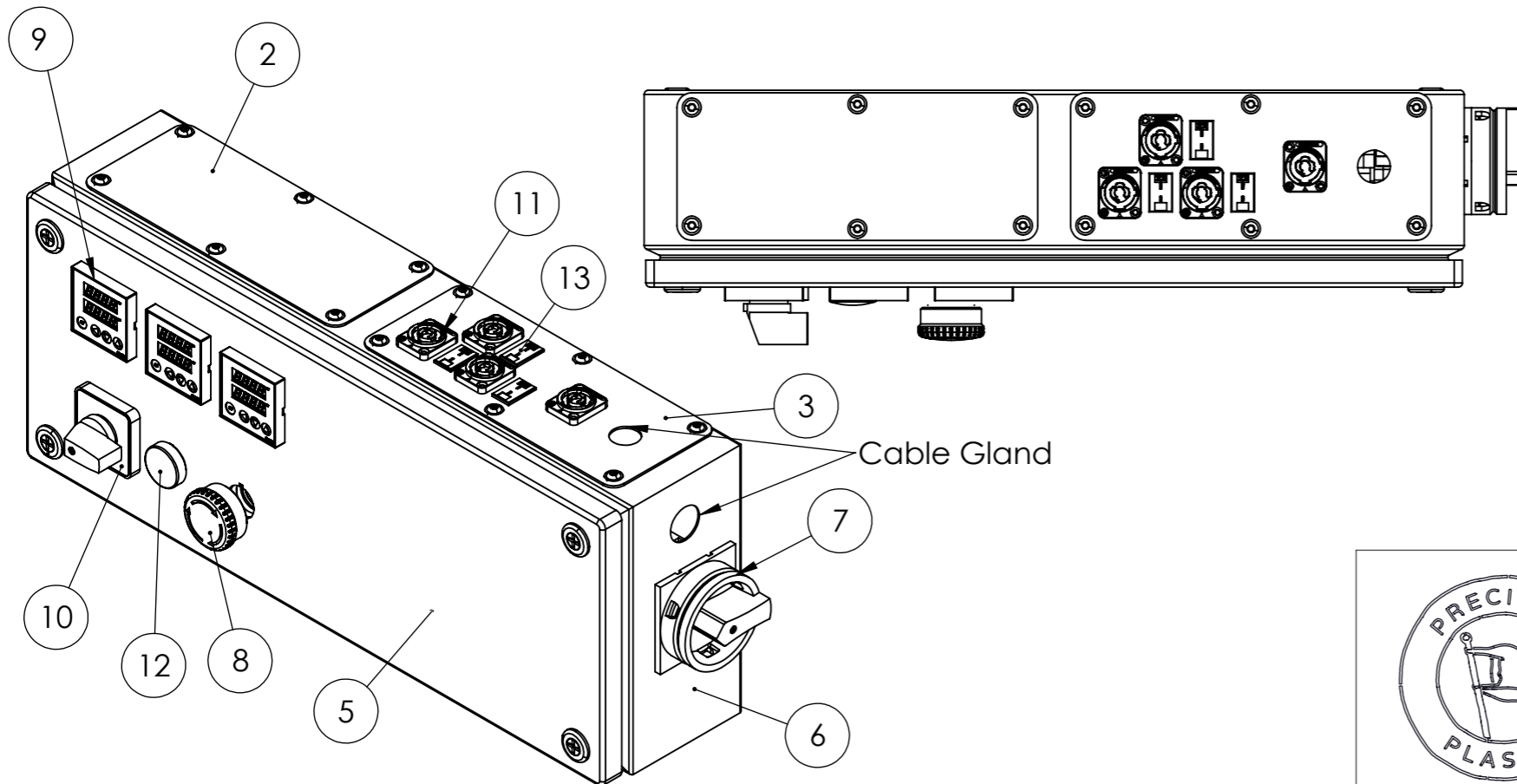
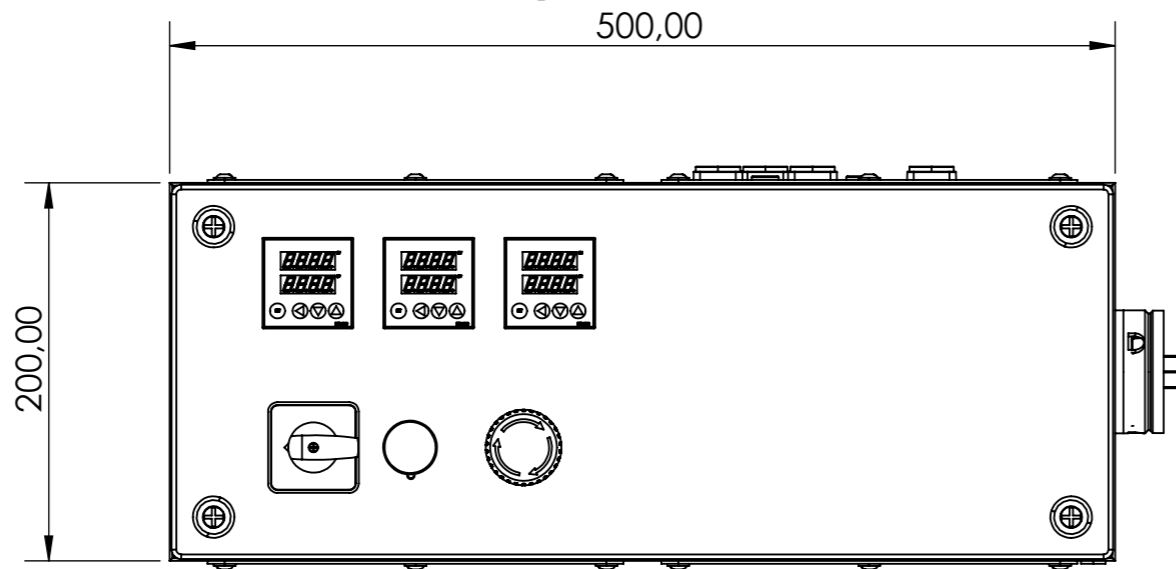
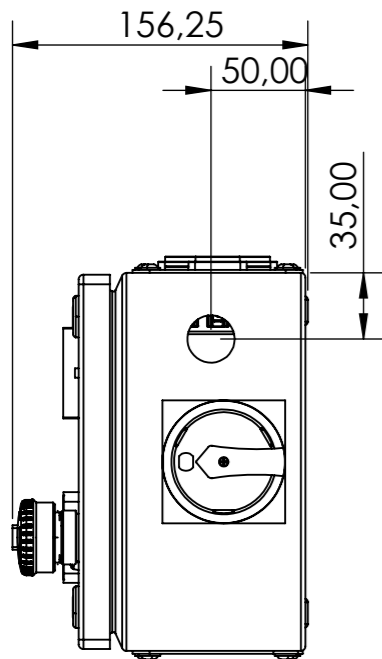
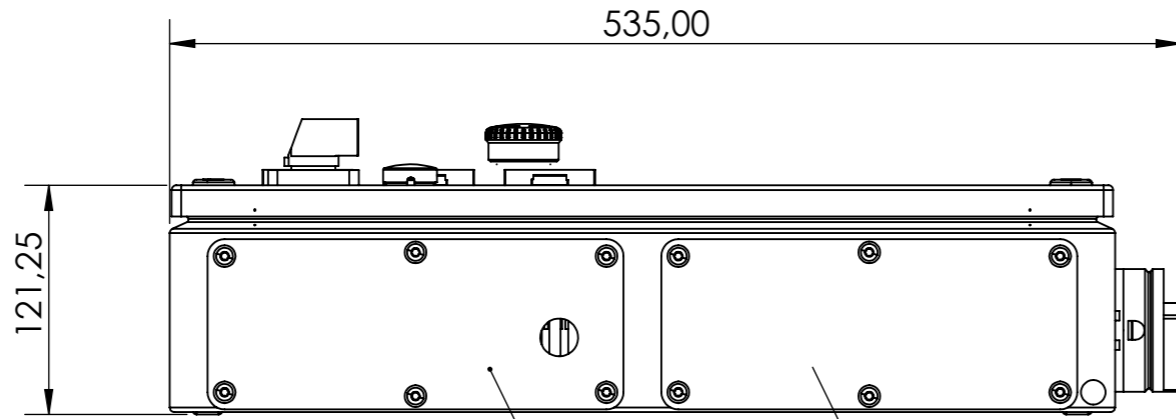

Check the separate BOM in the download kit for a detailed component list with article numbers, suppliers and specifications.



Weight	7773.80 g	Material	Material <not specified>				
Machine	Extruder Pro	Description	Electronics Box				
Projection method:	First angle	Release date	1-4-2022	Drawing no:	EXTPRO-1 2000.00-2	Rev.	A
General tolerances	Geometrical Tolerances: ISO 2768-m	Doc. type	Assembly	Units unless specified	mm/g	Sheet size	A3
General surface finish:	$\sqrt{6.4}$	Scale	1:4	Sheet	1/2		

8

7

6

5

4

3

2

1

8

7

6

5

4

3

2

1

F

F

E

E

D

D

C

C

B

B

A

A

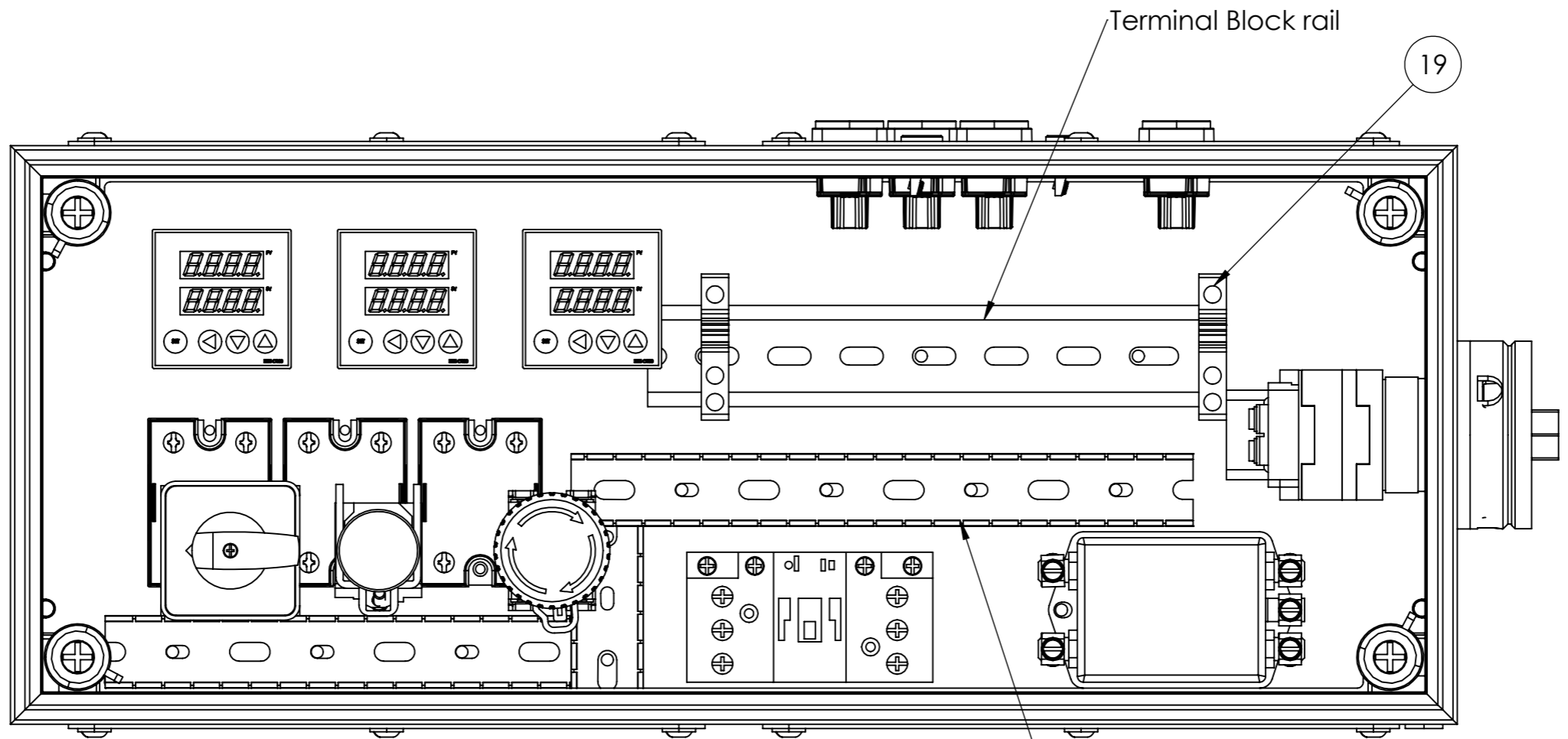

Terminal Block rail

19

Cable tray

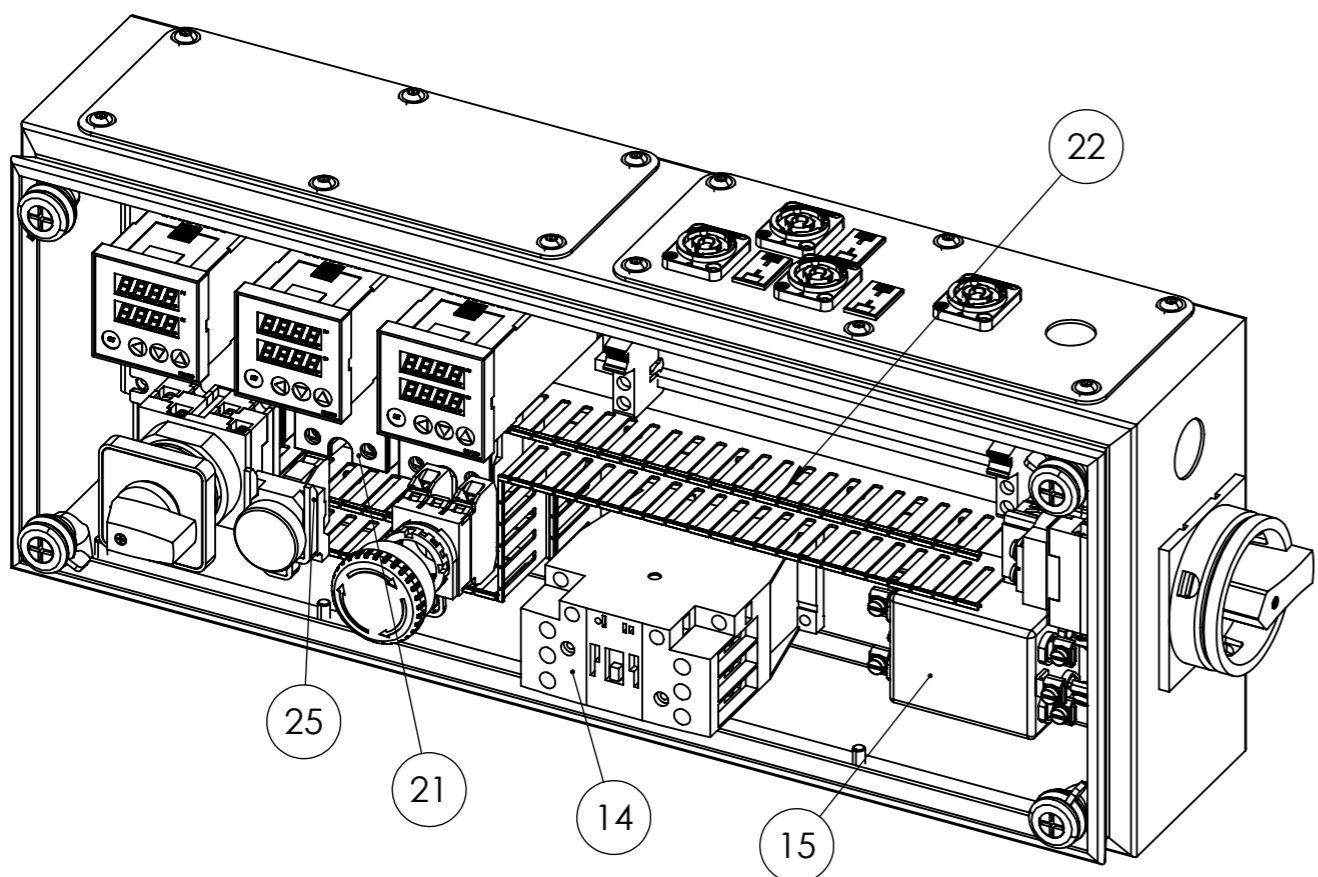

22

25

21

14

15



Weight		7773.80 g		Material		Material <not specified>	
Machine		Extruder Pro		Description		Electronics Box	
Projection method:		First angle 		Release date		Drawing no:	
General tolerances		Geometrical Tolerances: ISO 2768-m		24-2-2022		EXTPRO-1 2000.00-2	
General surface finish: $\sqrt{6.4}$		Doc. type		Units unless specified		Sheet size	
		Assembly		mm/g		A3	
				Scale		1:2	
				Rev.		A	
				Sheet		2/2	

8

7

6

5

4

3

2

1