

6

5

4

3

2

1

ITEM NO.	PART NUMBER	QTY.
1	DriveShaft	1
2	shaft locknut v4 style	2
3	19_RETAINING-WASHER_x4_8mm_FERRO	2
4	13 Blade	19
5	25_BLADE-SPACER_x38_4mm_FERRO	19
6	26_BLADE-SPACER-b_x38_2.5mm_FERRO	19

D

D

C

C

B

B

A

A

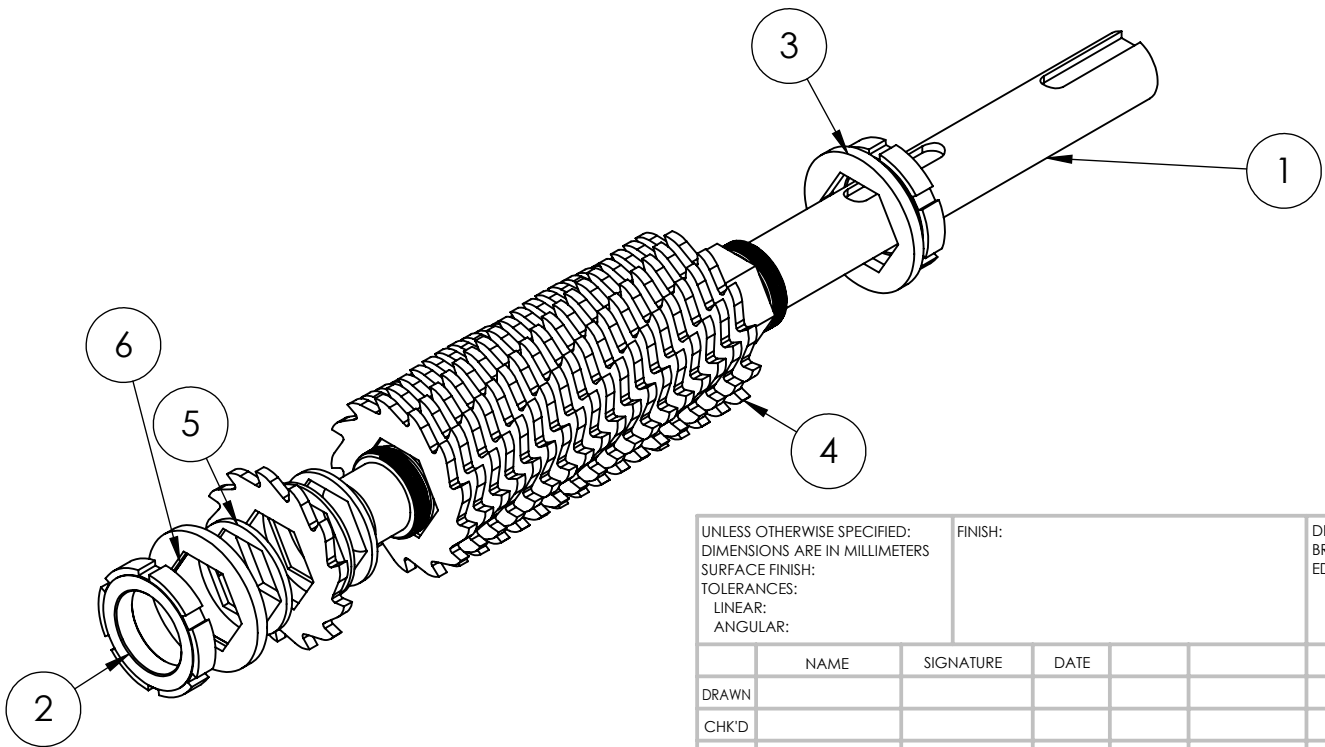

UNLESS OTHERWISE SPECIFIED: DIMENSIONS ARE IN MILLIMETERS SURFACE FINISH: TOLERANCES: LINEAR: ANGULAR:			FINISH:		DEBURR AND BREAK SHARP EDGES		DO NOT SCALE DRAWING		REVISION		
DRAWN			NAME		SIGNATURE		DATE		TITLE:		
CHK'D									DWG NO. 160_MobileKnives A4		
APPV'D											
MFG											
Q.A											
					MATERIAL:				SCALE:1:10		
							WEIGHT:		SHEET 1 OF 1		

6

5

4

3

2

1